

IS : 10086 - 1982

Indian Standard

**SPECIFICATION FOR
MOULDS FOR USE IN TESTS OF
CEMENT AND CONCRETE**

Second Reprint DECEMBER 1995

UDC 666'9'055 : 621'744'3 : 620'173/'174

© *Copyright* 1982

**BUREAU OF INDIAN STANDARDS
MANAK BHAVAN, 9 BAHADUR SHAH ZAFAR MARG
NEW DELHI 110002**

Indian Standard

SPECIFICATION FOR MOULDS FOR USE IN TESTS OF CEMENT AND CONCRETE

Cement and Concrete Sectional Committee, BDC 2

<i>Chairman</i>	<i>Representing</i>
DR H. C. VISVESVARAYA	Cement Research Institute of India, New Delhi
<i>Members</i>	
ADDITIONAL DIRECTOR, STANDARDS (B & S)	Research, Designs & Standards Organization (Ministry of Railways), Lucknow
DEPUTY DIRECTOR, STANDARDS (B & S) (<i>Alternate</i>)	
SHRI K. P. BANERJEE	Larsen & Toubro Ltd, Bombay
SHRI HARISH N. MALANI (<i>Alternate</i>)	
SHRI S. K. BANERJEE	National Test House, Calcutta
SHRI R. N. BANSAL	Beas Designs Organization, Nangal Township
SHRI T. C. GARG (<i>Alternate</i>)	
SHRI R. V. CHALAPATHI RAO	Geological Survey of India, Calcutta
SHRI S. ROY (<i>Alternate</i>)	
CHIEF ENGINEER (DESIGNS)	Central Public Works Department, New Delhi
EXECUTIVE ENGINEER (DESIGNS) III (<i>Alternate</i>)	
CHIEF ENGINEER (PROJECTS)	Irrigation Department, Government of Punjab, Chandigarh
DIRECTOR, IPRI (<i>Alternate</i>)	
DIRECTOR (CSMRS)	Central Soil and Materials Research Station, New Delhi
DEPUTY DIRECTOR (CSMRS) (<i>Alternate</i>)	
SHRI T. A. E. D'SA	The Concrete Association of India, Bombay
SHRI N. C. DUGGAL (<i>Alternate</i>)	
SHRI A. K. GUPTA	Hyderabad Asbestos Cement Products Ltd, Hyderabad
SHRI V. K. GUPTA	Engineer-in-Chief's Branch, Army Headquarters, New Delhi
SHRI S. N. PANDE (<i>Alternate</i>)	
DR R. R. HATTIANGADI	The Associated Cement Companies Ltd, Bombay
SHRI P. J. JAGUS (<i>Alternate</i>)	

(*Continued on page 2*)

© Copyright 1982

BUREAU OF INDIAN STANDARDS

This publication is protected under the *Indian Copyright Act* (XIV of 1957) and reproduction in whole or in part by any means except with written permission of the publisher shall be deemed to be an infringement of copyright under the said Act.

(Continued from page 1)

<i>Members</i>	<i>Representing</i>
DR IQBAL ALI	Engineering Research Laboratories, Hyderabad
SHRI S. R. KULKARNI	M. N. Dastur & Co Pvt Ltd, Calcutta
SHRI S. K. LAHA	The Institution of Engineers (India), Calcutta
SHRI B. T. UNWALLA (<i>Alternate</i>)	
DR MOHAN RAI	Central Building Research Institute (CSIR), Roorkee
DR S. S. REHSI (<i>Alternate</i>)	
SHRI K. K. NAMBIAR	In personal capacity (' Ramanalaya ' 11 First Crescent Park Road, Gandhinagar, Adyar, Madras)
SHRI H. S. PASRICHA	Hindustan Prefab Ltd, New Delhi
SHRI C. S. MISHRA (<i>Alternate</i>)	
SHRI Y. R. PHULL	Central Road Research Institute (CSIR), New Delhi
SHRI M. R. CHATTERJEE (<i>Alternate I</i>)	
SHRI K. L. SETHI (<i>Alternate II</i>)	
DR M. RAMAIAH	Structural Engineering Research Centre (CSIR), Roorkee
DR N. S. BHAL (<i>Alternate</i>)	
SHRI G. RAMDAS	Directorate General of Supplies and Disposals, New Delhi
DR A. V. R. RAO	National Buildings Organization, New Delhi
SHRI J. SEN GUPTA (<i>Alternate</i>)	
SHRI T. N. S. RAO	Gammon India Ltd, Bombay
SHRI S. R. PINHEIRO (<i>Alternate</i>)	
REPRESENTATIVE	Indian Roads Congress, New Delhi
SHRI ARJUN RIJHSINGHANI	Cement Corporation of India Ltd, New Delhi
SHRI K. VITHAL RAO (<i>Alternate</i>)	
SECRETARY	Central Board of Irrigation and Power, New Delhi
DEPUTY SECRETARY (I) (<i>Alternate</i>)	
SHRI N. SIVAGURU	Roads Wing, Ministry of Shipping and Transport, New Delhi
SHRI R. L. KAPOOR (<i>Alternate</i>)	
SHRI K. A. SUBRAMANIAM	The India Cements Ltd, Madras
SHRI P. S. RAMACHANDRAN (<i>Alternate</i>)	
SUPERINTENDING ENGINEER (DESIGNS)	Public Works Department, Government of Tamil Nadu, Madras
EXECUTIVE ENGINEER (SM&R DIVISION) (<i>Alternate</i>)	
SHRI L. SWAROOP	Dalmia Cement (Bharat) Ltd, New Delhi
SHRI A. V. RAMANA (<i>Alternate</i>)	
SHRI G. RAMAN, Director (Civ Engg)	Director General, ISI (<i>Ex-officio Member</i>)

Secretary.

SHRI M. N. NEELAKANDHAN
Assistant Director (Civ Engg), ISI

(Continued on page 19)

Indian Standard

SPECIFICATION FOR MOULDS FOR USE IN TESTS OF CEMENT AND CONCRETE

0. FOREWORD

0.1 This Indian Standard was adopted by the Indian Standards Institution on 28 January 1982, after the draft finalized by the Cement and Concrete Sectional Committee, had been approved by the Civil Engineering Division Council.

0.2 The Indian Standards Institution has already published a series of standards on methods of testing cement and concrete. It has been recognized that reproducible and repeatable test results can be obtained only with standard testing equipment capable of giving the desired level of accuracy. The Sectional Committee has, therefore, decided to bring out a series of specifications covering the requirements of equipment used for testing cement and concrete, to encourage their development and manufacture in the country.

0.3 Accordingly, this standard has been prepared to cover requirements of the moulds used for casting cement or concrete cubes, cylinders and beams for compressive and flexural strength tests on cement and concrete. The Indian Standards which detail the methods of compressive and flexural strength tests requiring use of these moulds are IS : 516-1959*, IS : 1199-1959† and IS : 4031-1968‡.

0.4 In the formulation of this standard, due weightage has been given to international co-ordination among the standards and practices prevailing in different countries in addition to relating it to the practices in the field in this country.

0.5 For the purpose of deciding whether a particular requirement of this standard is complied with, the final value, observed or calculated, expressing the result of a test or analysis, shall be rounded off in accordance with IS : 2-1960§. The number of significant place retained in the rounded off value should be the same as that of the specified value in this standard.

*Methods of test for strength of concrete.

†Methods of sampling and analysis of concrete.

‡Methods of physical tests for hydraulic cement.

§Rules for rounding off numerical values (*revised*).

1. SCOPE

1.1 This standard covers the requirements of the moulds used for casting cement or concrete cubes, cylinders and beams for tests of cement and concrete, such as compressive strength test and flexural strength test.

1.2 Moulds which are accessories to testing equipment such as vibration machine and jolting apparatus are not covered by this standard.

2. TYPES

2.1 The moulds shall be of following types:

- a) Cube moulds of 50, 100, 150, 225 and 300 mm,
- b) Cylindrical mould of 150 mm diameter and 300 mm height,
- c) Beam moulds of $100 \times 100 \times 500$ mm and $150 \times 150 \times 700$ mm,
- d) Bar moulds of 25×25 mm size and 250 mm effective length, and
- e) Mould of 75×75 mm size and 150 to 300 mm length.

3. MATERIAL

3.1 Material for construction of moulds shall normally be as given in Table 1. However, any other material which is non-absorbent and non-reactive with concrete and which shall retain the dimensional stability of the moulds may also be used.

4. DIMENSIONS AND TOLERANCES

4.1 The dimensions with tolerances of various types of moulds described at 2.1 (a) to 2.1 (d) (see Fig. 1 to 8) shall be as given in Tables 2 to 5. The dimensions of moulds described at 2.1 (e) shall be such that it shall be possible to cast specimens with a length of 150 to 300 mm and a cross-section as near as practicable to 75×75 mm.

NOTE — The allowable deviations for nominal dimensions shall be as laid down for coarse class of deviation in IS : 2102-1969*.

5. CONSTRUCTION

5.1 General — The construction of the moulds shall, in general, be in accordance with Fig. 1 to 8.

NOTE — The figures are illustrative only, but the dimensions and minimum requirements where specified shall be binding.

5.1.1 The moulds shall be of metal and stout enough to prevent distortion. These shall be constructed in such a manner as to facilitate the removal of the moulded specimen without damage and shall be so machined that, when they are assembled ready for use, the dimensions and internal faces shall be accurate within the specified limits. Internal faces of the moulds shall be smooth.

*Allowable deviations for dimensions without specified tolerances (first revision).

5

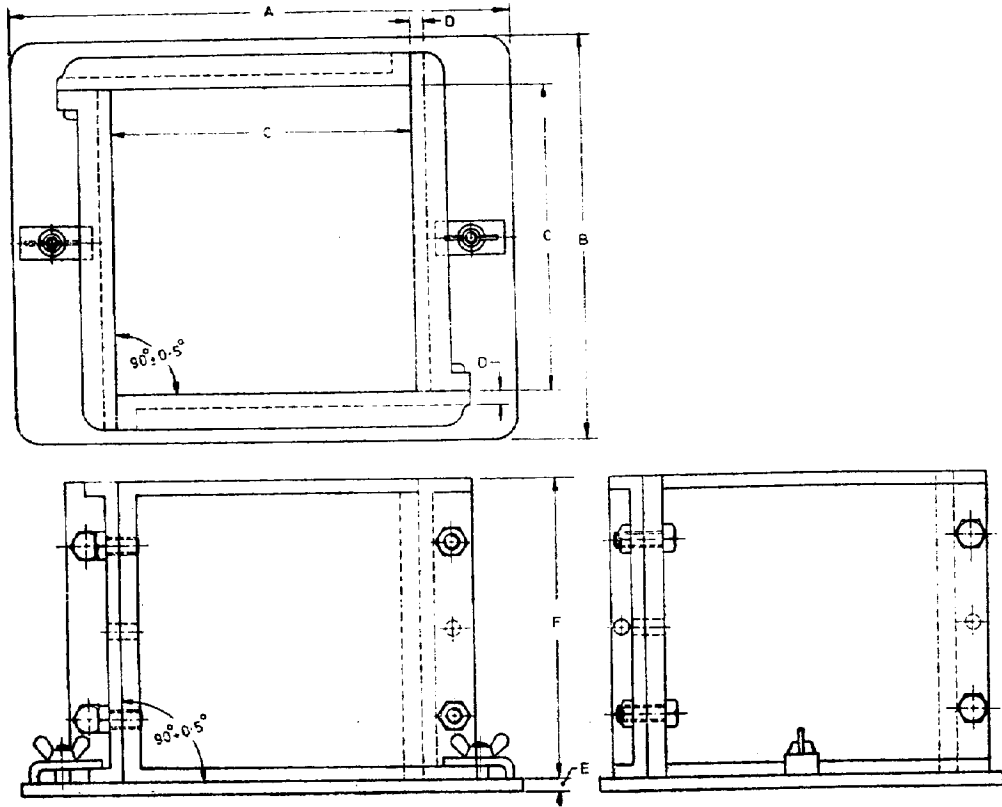

(For dimensions see Table 2)
FIG. 1 TYPICAL CUBE MOULD

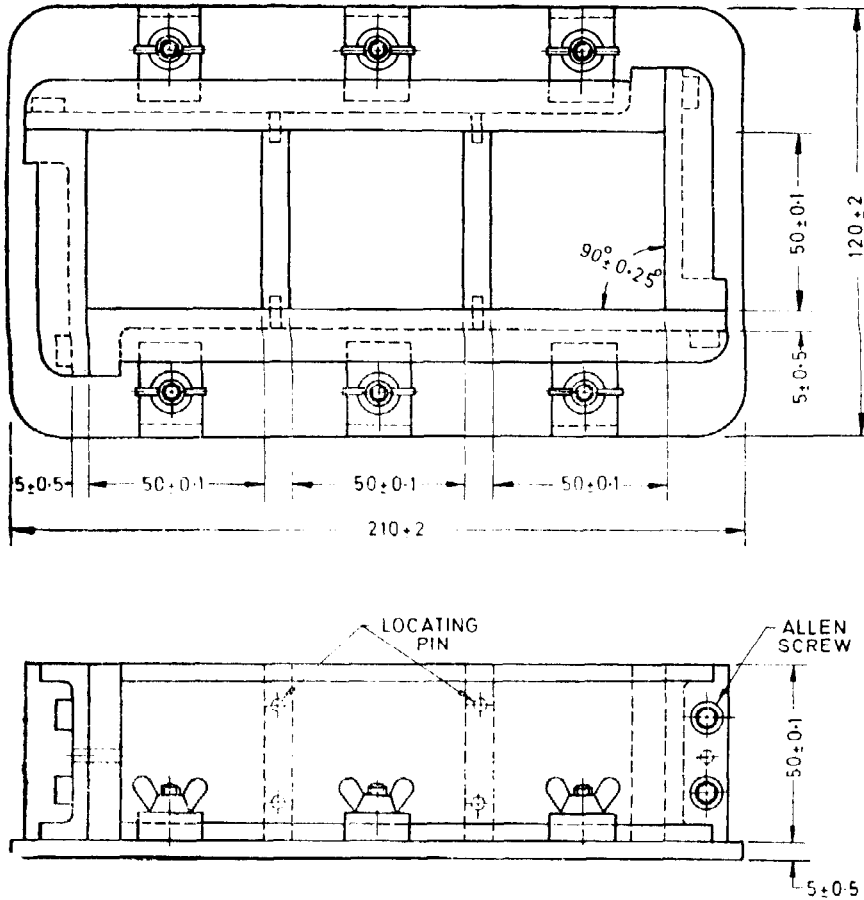

All dimensions in millimetres.

FIG. 2 TYPICAL CUBE MOULD, 50mm SIZE WITH 3 MOULD COMPARTMENT

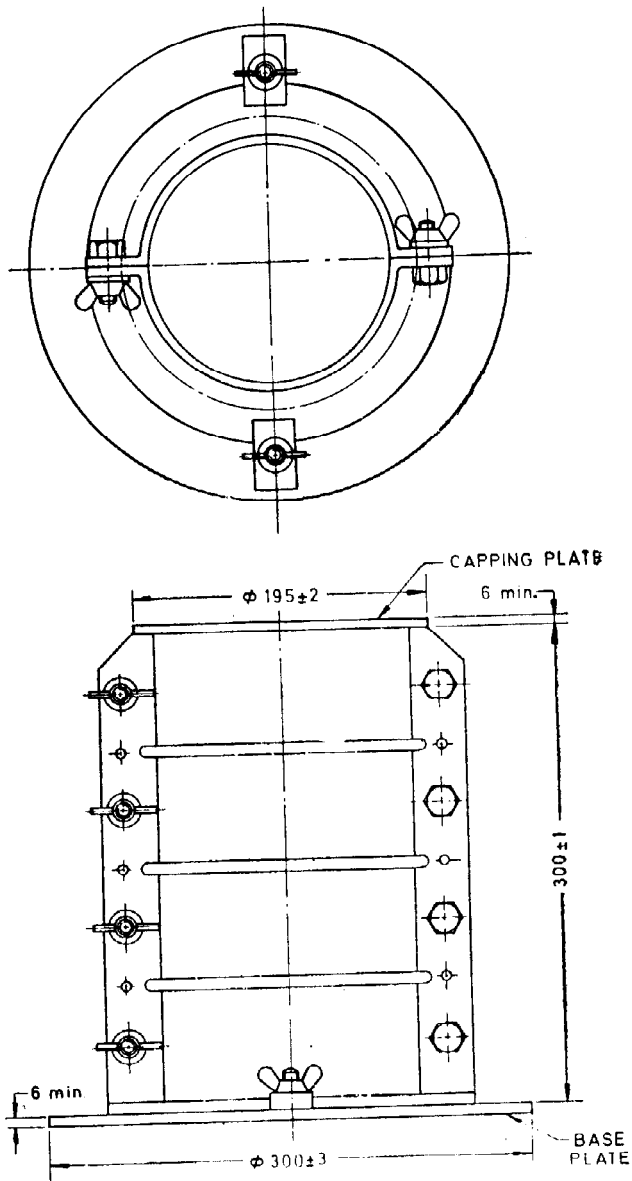

All dimensions in millimetre.

FIG. 3 TYPICAL CYLINDRICAL MOULD

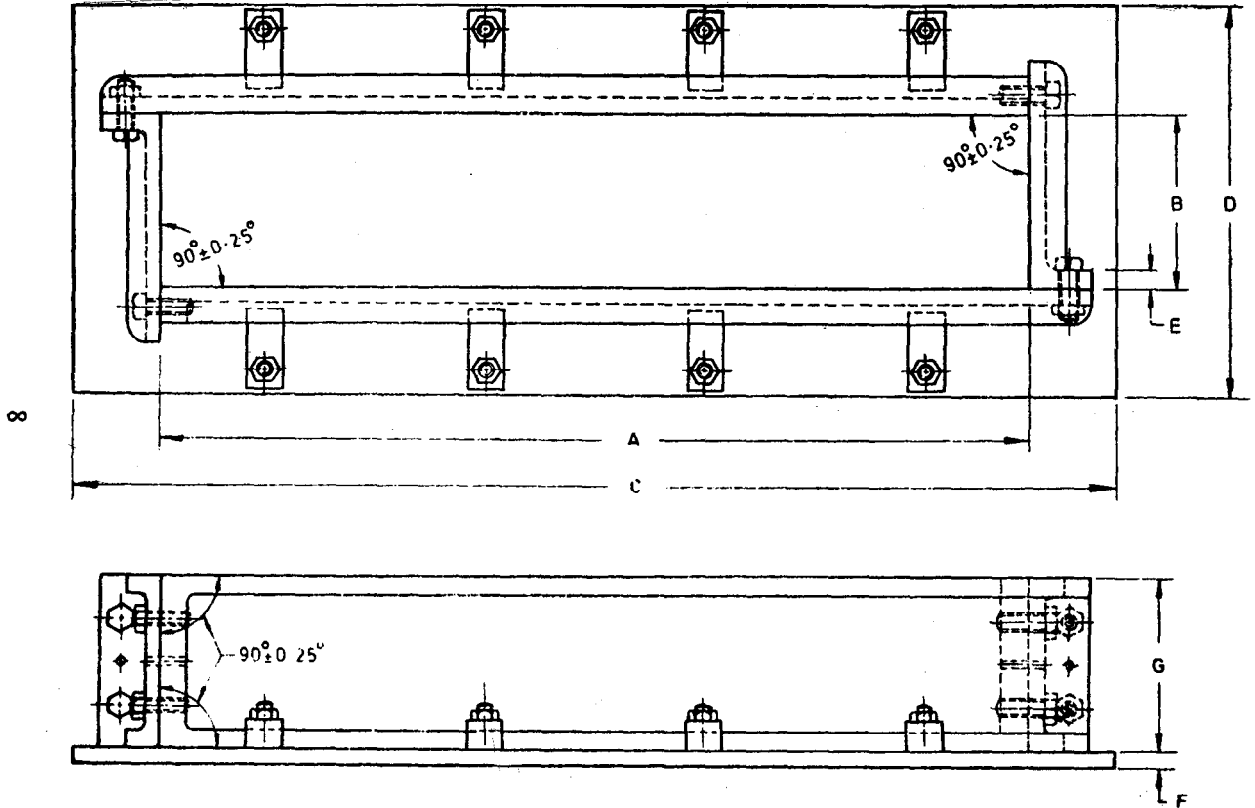
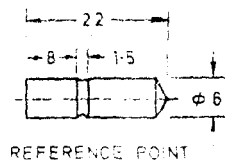
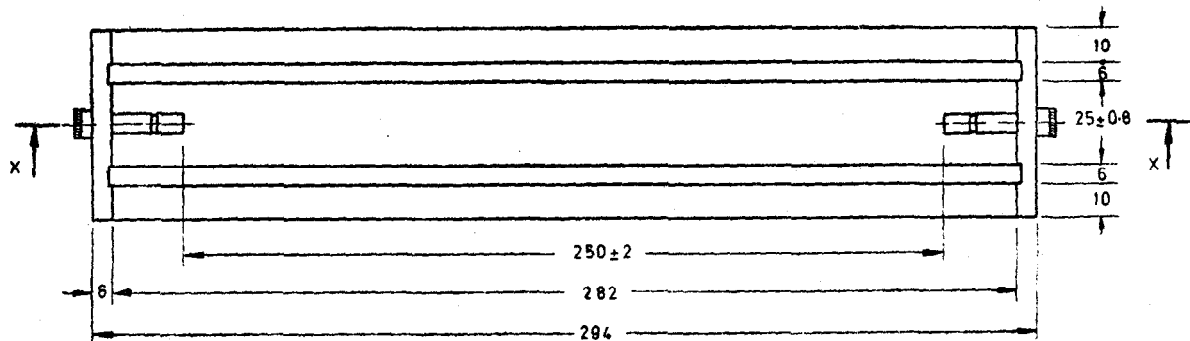

FIG. 4 TYPICAL BEAM MOULD



SECTION XX

All dimensions in millimetres.

FIG. 5 TYPICAL BAR MOULD

10

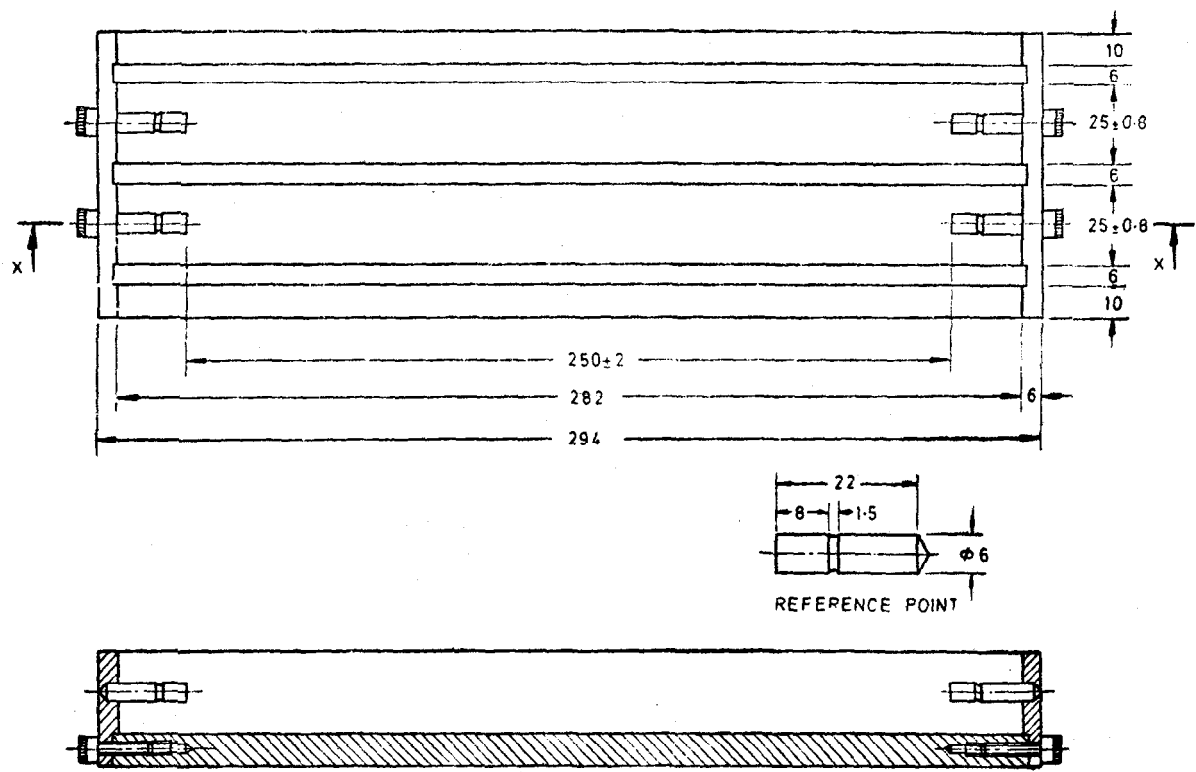

SECTION XX

All dimensions in millimetres.

FIG. 6 TYPICAL BAR MOULD (TWO MOULD COMPARTMENTS)

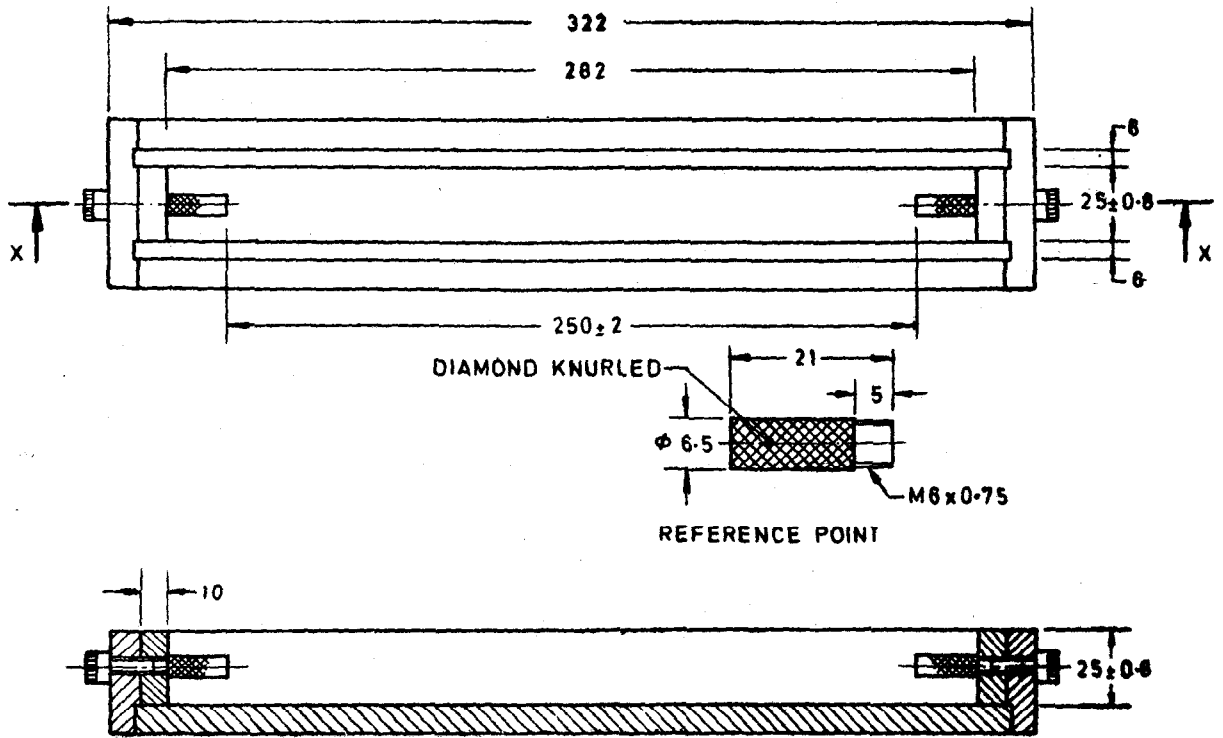

DIAMOND KNURLED

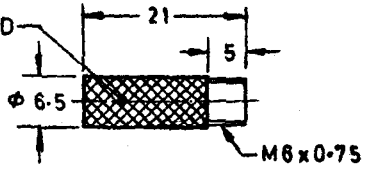

REFERENCE POINT

SECTION XX

All dimensions in millimetres.

FIG. 7 TYPICAL BAR MOULD

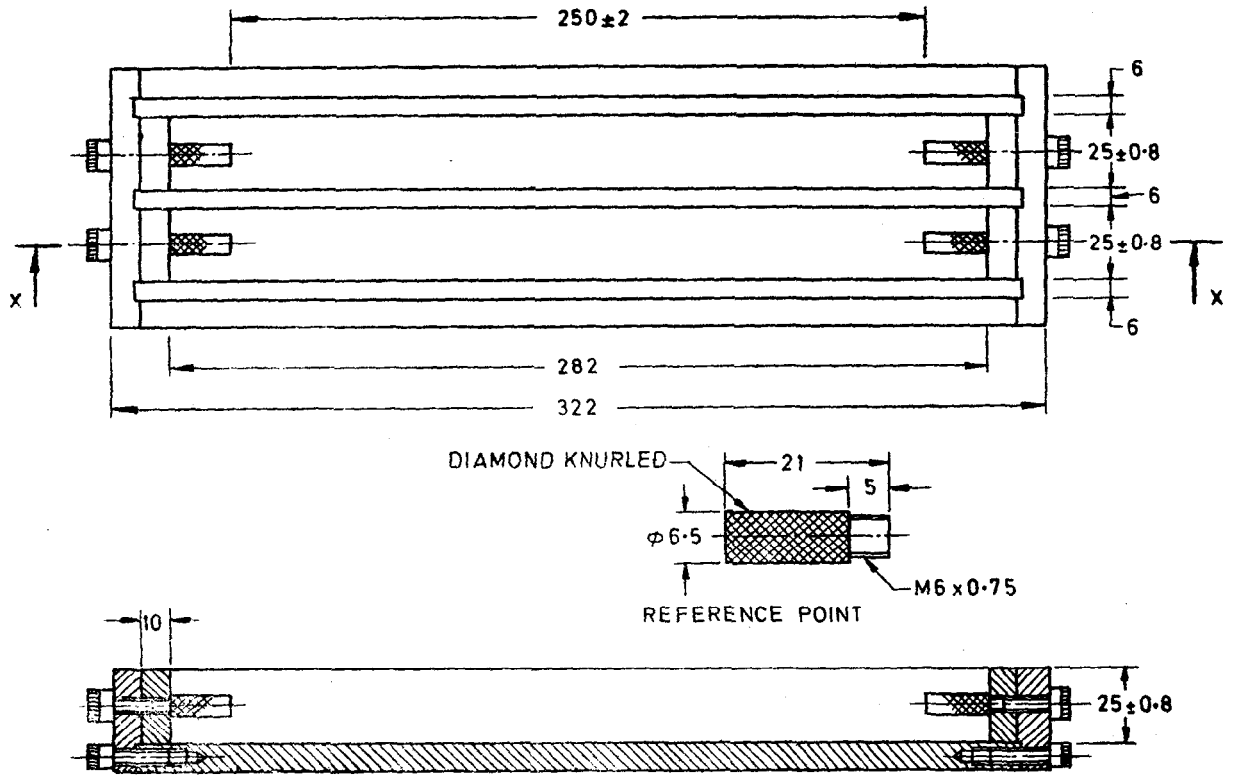

15

SECTION XX

All dimensions in millimetres.

FIG. 8 TYPICAL BAR MOULD (TWO MOULD COMPARTMENTS)

TABLE 1 MATERIALS OF CONSTRUCTION OF MOULDS

(Clause 3.1)

Sl No.	MOULD TYPE	PART	MATERIAL	RECOMMENDED INDIAN STANDARD SPECIFICATION, IF ANY
(1)	(2)	(3)	(4)	(5)
i)	Cube mould, 50 mm	a) Side plate	Cast iron/ Mild steel	IS : 210-1978*/ IS : 226-1975†
		b) Base plate	Cast iron/ Mild steel	IS : 210-1978*/ IS : 226-1975†
ii)	Cube mould, 100 mm, 150 mm, 225 mm and 300 mm	a) Side plate b) Base plate	Cast iron Cast iron	IS : 210-1978* IS : 210-1978*
iii)	Cylindrical mould, 150 mm diameter × 300 mm height	a) Split part	Cast iron/ Mild steel	IS : 210-1978*/ IS : 226-1975†
		b) Base plate	Cast iron/ Mild steel	IS : 210-1978*/ IS : 226-1975†
		c) Capping plate	Cast iron/ Mild steel	IS : 210-1978*/ IS : 226-1975†
iv)	Beam mould 100 × 100 × 500 and 150 × 150 × 750 mm	a) Side plate	Cast iron	IS : 210-1978*
		b) Base plate	Cast iron	IS : 210-1978*
		c) Top plate	Mild steel	IS : 226-1975†
v)	Bar mould of 25 × 25 mm size and 250 mm effective length	a) Side plate	Mild steel	IS : 226-1975†
		b) Base plate	Mild steel	IS : 226-1975†
		c) Reference points (smooth & knurled)	Stainless steel	---
vi)	Mould of 75 × 75 mm size and 150 to 300 mm length	a) Side Plate	Mild steel	IS : 226-1975†
		b) Base plate	Mild steel	IS : 226-1975†

* Specification for grey iron castings (*third revision*).† Specification for structural steel (*standard quality*) (*fifth revision*).

TABLE 2 DIMENSIONS AND TOLERANCES OF CUBE MOULDS
(Clause 4.1)

Sl No.	DESCRIPTION	CUBE MOULD SIZE				
		50	100	150	225	300
(1)	(2)	(3)	(4)	(5)	(6)	(7)
i)	Distance between opposite faces (C^*), mm	50 ± 0.1	100 ± 0.2	150 ± 0.2	225 ± 0.3	300 ± 0.4
ii)	Height of mould (F^*), mm	50 ± 0.1	100 ± 0.2	150 ± 0.2	225 ± 0.3	300 ± 0.4
iii)	Thickness of wall plate (D^*), mm	6	8	8	10	10
iv)	Angle between adjacent interior faces and between interior faces and top and bottom plates of mould	$90 \pm 0.5^\circ$	$90 \pm 0.5^\circ$	$90 \pm 0.5^\circ$	$90 \pm 0.5^\circ$	$90 \pm 0.5^\circ$
v)	Length of base plate (A^*), mm	120	225	280	375	425
vi)	Width of base plate (B^*), mm	95	165	215	300	375
vii)	Thickness of base plate (E^*) mm	6	8	8	10	12
viii)	Permissible variation in the planeness of interior faces :					
	for new moulds, mm	0.03	0.03	0.03	0.03	0.03
	for moulds in use, mm	0.05	0.05	0.05	0.05	0.05
ix)	Permissible variation in the planeness of base plate, mm	0.1	0.03	0.03	0.03	0.03

* These letter symbols are indicated in Fig 1.

TABLE 3 DIMENSIONS AND TOLERANCES FOR CYLINDRICAL MOULDS
(Clause 4.1)

Sl No.	DESCRIPTION	DIMENSIONS IN mm
(1)	(2)	(3)
i)	Mean internal diameter	150 ± 0.2
ii)	Actual internal diameter in any direction	150 ± 0.5
iii)	Height	300 ± 1
iv)	Permissible variation in the planeness of cylindrical wall plate	0.05
v)	Thickness of wall plate	6
vi)	Diameter of base plate	300 ± 3
vii)	Diameter of capping plate	195 ± 2
viii)	Thickness of base plate/capping plate	6
ix)	Permissible variation in the planeness of base plate/capping plate	0.03

TABLE 4 DIMENSIONS AND TOLERANCES OF BEAM MOULDS
(Clause 4.1)

Sl No.	DESCRIPTION	BEAM MOULD SIZE	
		100×100×500	150×150×700
(1)	(2)	(3)	(4)
i)	Length between internal faces (A*), mm	500	700
ii)	Width between internal faces (B*), mm	100 ± 0.2	150 ± 0.2
iii)	Height (G*), mm	100 ± 0.05	150 ± 0.05
iv)	Thickness of wall plate (E*), mm	9	12
v)	Length of base plate (C*), mm	600	830
vi)	Width of base plate (D*), mm	225	275
vii)	Thickness of base plate (F*), mm	8	10
viii)	Angle between interior faces and top and bottom planes of the mould	90 ± 0.5°	90 ± 0.5°
ix)	Permissible variation in the planeness of internal surfaces:		
	In a length of 150 mm, mm	0.03	0.03
	Overall, mm	0.1	0.1

*These letter symbols are indicated in Fig. 4.

TABLE 5 DIMENSIONS AND TOLERANCES OF BAR MOULDS
(Clause 4.1)

Sl No.	DESCRIPTION	DIMENSIONS IN mm
(1)	(3)	(3)
i)	Distance between inner ends of reference points (effective gauge length)	250 ± 2
ii)	Width between inner surfaces	25 ± 0.8
iii)	Height	25 ± 0.8

NOTE — The dimensions given in the table shall also apply to moulds in use.

5.1.2 The inside faces of the mould plates and base plates may have blowholes and blemishes on the surface, such as honey-combing. All such blowholes and cavities shall be fitted in with mild steel pins, or by welding and shall be finished flush with the surface either by machining or by filing. However, the number of blowholes on each plate acceptable may not exceed 5 in the case of cube moulds of up to and including size 150 mm; and 10 in the case of cube moulds of sizes 225 and 300 mm, cylindrical mould of 150 mm diameter and 300 mm height and beam moulds of sizes $100 \times 100 \times 500$ mm and $150 \times 150 \times 700$ mm. The sizes of the blowhole in any direction may not exceed 5 mm with a depth of 3 to 5 mm. In the case of cylindrical mould, the sizes of blowhole/cavity in any direction may not exceed 20-25 mm.

5.2 Special Requirements

5.2.1 Cube Mould — Cube mould of 50 mm size shall be either a single mould (see Fig. 1) or with more than one mould compartment (see Fig. 2); however, the number of mould compartments shall not exceed 3. Cube moulds of size 100 mm, 150 mm, 225 mm and 300 mm shall be made in such a manner as to facilitate their separation into two parts. Cube moulds shall be provided with a base plate.

NOTE — If required by the purchaser, cube moulds may be provided with flat steel cover plates to facilitate accelerated curing of test specimens (see IS : 9013-1978*).

5.2.2 Cylindrical Mould (see Fig. 3) — shall be made in such a manner as to facilitate separation of the mould longitudinally into two parts. Each mould shall be provided with a base plate and a capping plate.

5.2.3 Beam Mould (see Fig. 4) — shall be made in such a manner as to facilitate separation of the mould into two parts. The mould shall be constructed with the longer dimension horizontal. Each mould shall be provided with a base plate.

5.2.4 Bar Mould — The bar mould may be a single one or with more than one mould compartment. Each end plate of the mould shall be equipped to hold properly in place a stainless steel reference point having a diameter of 6 mm. The reference points may be either smooth or knurled end threaded. The reference points shall be so set that their principal axis coincides with the principal axis of the mould and shall extend 16 mm inside the mould. Each mould shall be provided with a base plate. Typical bar moulds are shown in Fig. 5, 6, 7 and 8.

5.3 Arrangement for Fastening/Clamping — The base plate shall preferably be attached to the mould by cleats which may either be spring-loaded or secured with threaded studs and nuts/wing nuts. The parts of the mould,

*Method of making, curing and determining compressive strength of accelerated-cured concrete test specimens.

when assembled, shall be positively and rigidly held together during filling, subsequent handling and vibration where applicable. Any suitable method of ensuring this by way of lock nuts and/or locating pins may be employed.

6. ACCESSORIES

6.1 Tamping Rod — The tamping rod shall be of the following types:

- a) 16 ± 0.5 mm dia and 600 ± 2 mm long with a rounded working end shall be made of mild steel (see Fig. 9),
- b) Of square section with tamping face 25 ± 0.5 mm square and 400 ± 2 mm long and weighing 2 kg shall be made of mild steel and provided with a handle (see Fig. 10).
- c) Of 12×25 mm cross-section and convenient length of 125 to 150 mm; tamping face shall be flat and at right angles to the length of the bar; shall be made of non-absorbent, abrasion resistant non-brittle material, such as a rubber compound having a Shore A Durometer hardness of 80 ± 10 or seasoned teak wood rendered non-absorbent by immersion for 15 min in paraffin at approximately 200°C , or ebonite fibre.

6.2 Gauging Trowel — The gauging trowel shall be made of mild steel and shall be in accordance with Fig. 11. The trowel blade shall be of minimum thickness 1.5 mm and of length 195 mm and shall be provided with a wooden handle. The trowel shall weigh 210 ± 10 g.

6.3 Trowel — The trowel shall be made of mild steel and shall be in accordance with Fig. 11. The trowel blade shall be of minimum thickness 1.5 mm and 100 to 150 mm length with straight edges.

7. MARKING

7.1 The following information shall be clearly and indelibly marked on each component of the mould as far as practicable in way that it does not interfere with the performance of the mould.

- a) Name of the manufacturer or his registered trade mark or both, and
- b) Date of manufacture.

7.1.1 The moulds may also be marked with the ISI Certification Mark.

NOTE — The use of the ISI Certification Mark is governed by the provisions of the Indian Standards Institution (Certification Marks) Act and the Rules and Regulations made thereunder. The ISI Mark on products covered by an Indian Standard conveys the assurance that they have been produced to comply with the requirements of that standard under a well-defined system of inspection, testing and quality control which is devised and supervised by ISI and operated by the producer. ISI marked products are also continuously checked by ISI for conformity to that standard as a further safeguard. Details of conditions under which a licence for the use of the ISI Certification Mark may be granted to manufacturers or processors, may be obtained from the Indian Standards Institution.

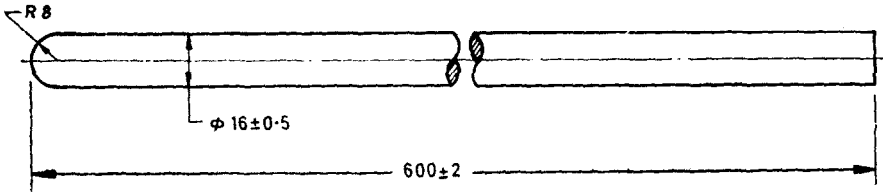

All dimensions in millimetres.

FIG. 9 TYPICAL TAMPING ROD

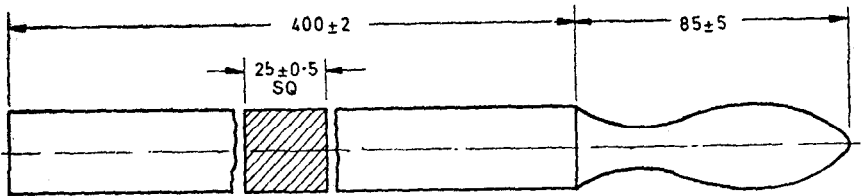

All dimensions in millimetres.

FIG. 10 TYPICAL TAMPING BAR

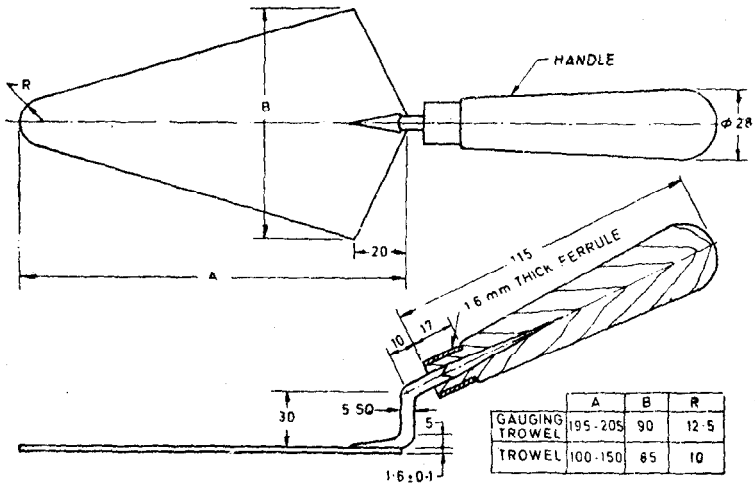

All dimensions in millimetres.

FIG. 11 TYPICAL TROWEL

(Continued from page 2)

Instruments for Cement and Concrete Testing Subcommittee, BDC 2 : 10

<i>Convener</i>	<i>Representing</i>
DR IQBAL ALI	Engineering Research Laboratories, Hyderabad
<i>Members</i>	
SHRI P. D. AGARWAL	Public Works Department, Government of Uttar Pradesh, Lucknow
DR T. N. CHOJER (<i>Alternate</i>)	
PROF B. M. AHUJA	Indian Institute of Technology, New Delhi
SHRI T. P. EKAMBARAM	Highways Research Station, Madras
SHRI H. K. GUHA	All India Instruments Manufacturers and Dealers Association, Bombay
<i>DEPUTY SECRETARY (Alternate)</i>	
SHRI P. J. JAGUS	The Associated Cement Companies Ltd, Bombay
SHRI D. A. WADIA (<i>Alternate</i>)	
SHRI M. R. JOSHI	Research & Development Organization (Ministry of Defence), Pune
SHRI Y. P. PATHAK (<i>Alternate</i>)	
SHRI E. K. RAMACHANDRAN	National Test House, Calcutta
SHRI S. K. BANERJEE (<i>Alternate</i>)	
PROF C. K. RAMESH	Indian Institute of Technology, Bombay
DR R. S. Ayyar (<i>Alternate</i>)	
SHRI M. V. RANGA RAO	Cement Research Institute of India, New Delhi
DR K. C. NARANG (<i>Alternate</i>)	
DR S. S. REHSI	Central Building Research Institute (CSIR), Roorkee
SHRI J. P. KAUSHISH (<i>Alternate</i>)	
SHRI A. V. S. R. SASTRI	Associated Instrument Manufacturers (India) Private Ltd, New Delhi
SHRI SUBHASH SHARMA (<i>Alternate</i>)	
SHRI K. L. SETHI	Central Road Research Institute (CSIR), New Delhi
SHRI M. L. BHATIA (<i>Alternate</i>)	

BUREAU OF INDIAN STANDARDS

Headquarters;

Manak Bhavan, 9 Bahadur Shah Zafar Marg, NEW DELHI 110002

Telephones : 331 01 31, 331 13 75

Telegrams : Manaksanatha
(Common to all offices)

Regional Offices:

	<i>Telephones</i>
Central : Manak Bhavan, 9 Bahadur Shah Zafar Marg, NEW DELHI-110002	[331 01 31 331 13 75
* Eastern : 1/14 C.I.T. Scheme VII M, V. I. P. Road, Maniktola, CALCUTTA 700054	36 24 99
Northern : SCO 445-446, Sector 35-C, CHANDIGARH 160036	[2 18 43 3 16 41
Southern : C. I. T. Campus, MADRAS 600113	{ 41 24 42 41 25 19 41 29 16
† Western : Manakalaya, E9 MIDC, Marol, Andheri (East), BOMBAY 400093	6 32 92 95

Branch Offices:

'Pushpak' Nurmohamed Shaikh Marg, Khanpur, AHMEDABAD 380001	[2 63 48 2 63 49
‡Peenya Industrial Area, 1st Stage, Bangalore Tumkur Road BANGALORE 560058	[38 49 55 38 49 56
Gangotri Complex, 5th Floor, Bhadbhada Road, T. T. Nagar. BHOPAL 462003	6 67 16
Plot No. 82/83, Lewis Road, BHUBANESHWAR 751002	5 36 27
63/5, Ward No. 29, R. G. Barua Road, 5th Byelane, GUWAHATI 781003	3 31 77
5-8-56C L. N. Gupta Marg (Nampally Station Road), HYDERABAD 500001	23 10 83
R14 Yudhister Marg, C Scheme, JAIPUR 302005	[6 34 71 6 98 32
117/418 B Sarvodaya Nagar, KANPUR 208005	[21 68 76 21 82 92
Patliputra Industrial Estate, PATNA 800013	6 23 05
T.C. No. 14/1421, University P.O., Palayam TRIVANDRUM 695035	[6 21 04 6 21 17
<i>Inspection Office (With Sale Point) :</i>	
Pushpanjali, 1st Floor, 205-A West High Court Road, Shankar Nagar Square, NAGPUR 440010	2 51 71
Institution of Engineers (India) Building. 1332 Shivaji Nagar, PUNE 411005	5 24 35
*Sales Office in Calcutta is at 5 Chowringhee Approach, P.O. Princep Street, Calcutta 700072	27 68 00
†Sales Office in Bombay is at Novelty Chambers, Grant Road, Bombay 400007	89 65 28
‡Sales Office in Bangalore is at Unity Building, Narasimharaja Square Bangalore 560002	22 36 71

AMENDMENT NO. 1 NOVEMBER 1984

TO

IS:10086-1982 SPECIFICATION FOR MOULDS FOR USE
IN TESTS OF CEMENT AND CONCRETE

Addendum

(Page 14, Table 2) - Add the following new note below the table:

'NOTE - The length and width of base plate depend upon the arrangement provided for clamping the mould to the base plate and hence may vary from the values specified in the table.'

(BDC 2)

Printed at Simco Printing Press, Delhi, India

AMENDMENT NO. 2 JUNE 1985

TO

IS:10086-1982 SPECIFICATION FOR MOULDS FOR USE IN
TESTS OF CEMENT AND CONCRETE

(Page 4, clause 4.1) - Renumber the existing NOTE as NOTE 1 and add the following as NOTE 2 under this clause:

'NOTE 2 - For checking the permissible variation in the planeness, the surface should be wholly contained between two planes not further apart than the specified value.'

(BDC 2)

Printed at Simco Printing Press, Delhi, India

AMENDMENT NO. 3 FEBRUARY 1988

TO

**IS:10086-1982 SPECIFICATION FOR MOULDS FOR USE
IN TESTS OF CEMENT AND CONCRETE**

(Page 17, clause 7.1, line 2) - Add the words 'and the accessories' after the words 'the mould'.

(Page 17, clause 7.1.1) - Add the words 'and the accessories' after the words 'The moulds'.

(BDC 2)

Printed at Simco Printing Press, Delhi, India

AMENDMENT NO. 4 MARCH 1993

TO

**IS 10086 : 1982 SPECIFICATION FOR MOULDS FOR
USE IN TESTS OF CEMENT AND CONCRETE**

(Page 4, clause 4.1) — Substitute 'IS 2102 (Part 1) : 1980' for 'IS : 2102 1969' in the NOTE.

(Page 4, foot-note) — Substitute the following for the existing foot-note:

'* General tolerances for dimensions and form and position: Part 1 General tolerances for linear and angular dimensions (*second revision*).'

(CED'2)

Printed at Simco Printing Press, Delhi